



**DATA SHEET
SPIRIT 135Hp
Direct Drive**

Document
E-DTD.W017.001

Edition

A

Revision

1

SPIRIT 135 DIRECT DRIVE

SPIRIT135

SKY LINE

MWFLY DIRECT DRIVE



Applicability



TRANSLATED

FREE DISCLOSURE

Page 1 of 6



DATA SHEET SPIRIT 135Hp Direct Drive

Document
E-DTD.W017.001

Edition
A

Revision
1

Engine data

Model/Code	Spirit 135 Direct Drive / W017 right rotation – W018 left rotation
Type	4 cylinder boxer - 4 Stroke fuel (Otto cycle)
Displacement [cm ³ (in ³)]	2201 (134)
Weight [Kg (lb)]	81 (178) dry (without accessories)
Dimension L x W x H [mm (in)]	590 x 762 x 419 (23.23 x 30 x 16.5)
Stroke X Bore [mm (in)]	81 x 93 (3.18 x 3.66)
Compression Rate	10.3 ÷ 1
Fuel	Mo.GAS min. AKI 90, R.O.N. 95, M.O.N. 85, LL100
Cooling System	Liquid with mechanical pump
Lubrication	Semi-dry sump, pressure oil feed assisted with internal pump
Timing System	2 valves per cylinder with S.O.H.C. (Single Over Head Camshaft)
Timing Driving System	Gear + chain with automatic chain tensioner
Accessories pre-installed	Engine wiring loom, voltage regulator, start relay, dampers, ign. coils

Transmission



Electric data

Generator	Permanent magnet, oil cooled, 300W (12.5V-24A)
Starter	Electric starter 0.65kW with anti-kickback clutch
F.R.I.S. (Full Redundancy Injector System)	ECU with dual injection and ignition; altitude and temperature compensation; Limp Home strategy
CAN Data Transmission	CAN Aerospace protocol

Performance

Max Power [kW (Hp)]	99.3 (135) @ 4700 rpm
Max Torque [Nm (Ft-lb)]	213 (157.1) @ 3120,500 rpm
Max Continuous Power [kW (Hp)]	88.3 (120)
Max Engine Speed [rpm]	4750
Power/Weight [Hp/Kg (Hp/lb)]	1.67 (0.76)
Fuel Cons. [Kg/h (lb/h)]	17.4 (38.4) @ 101 Hp (75%)
TBO [h]	1200

DIMENSIONS

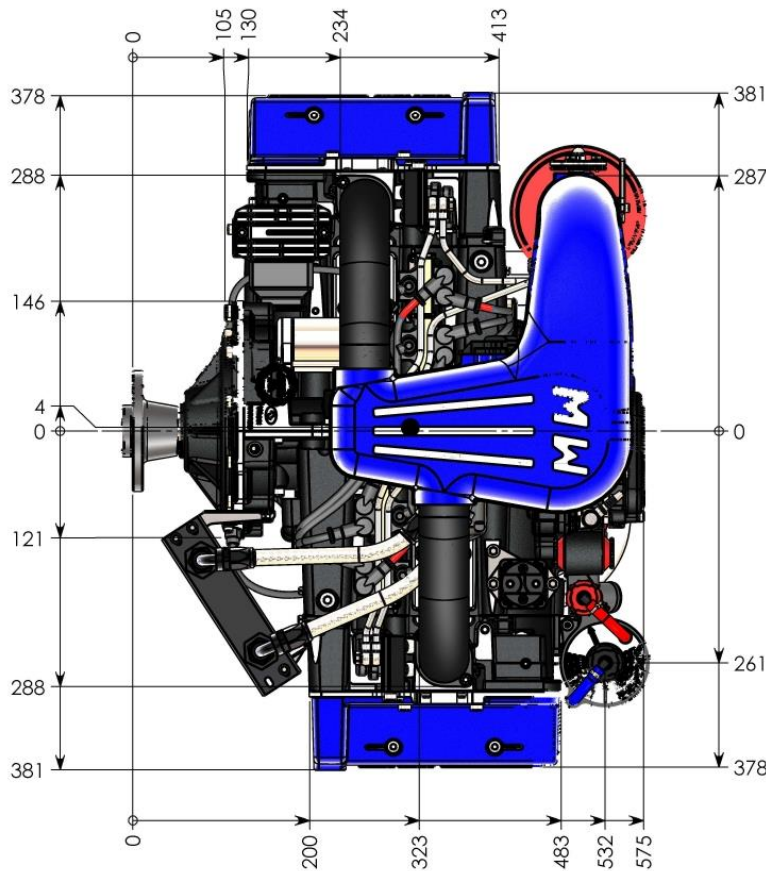
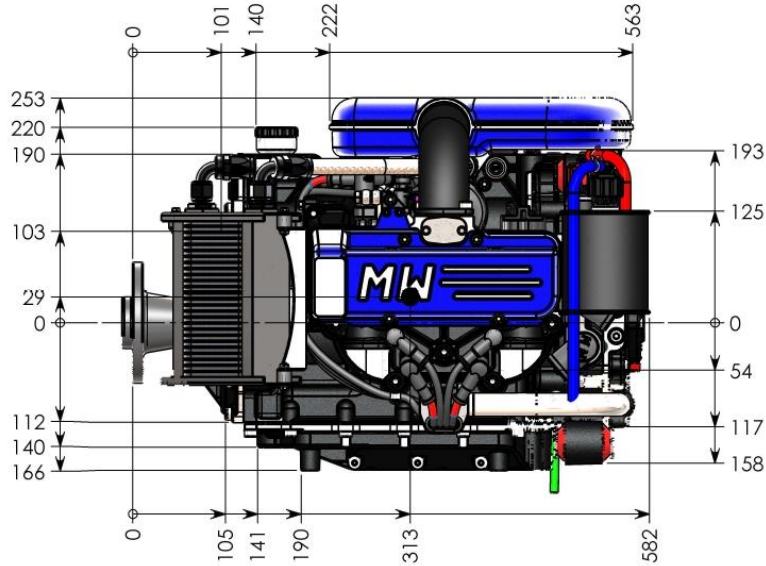

ATTACHMENT POINTS

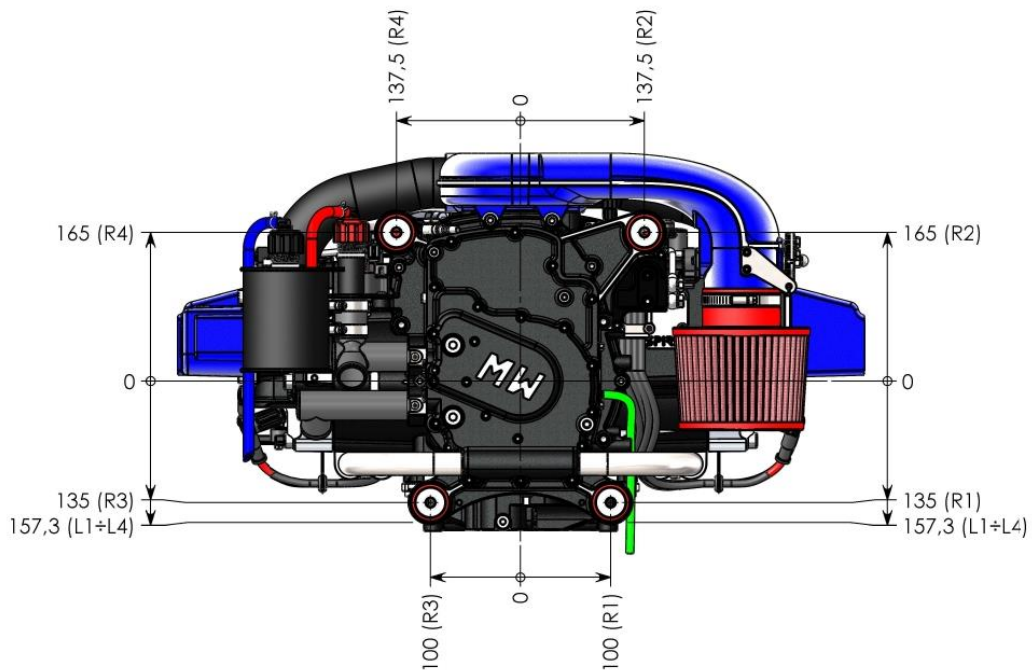
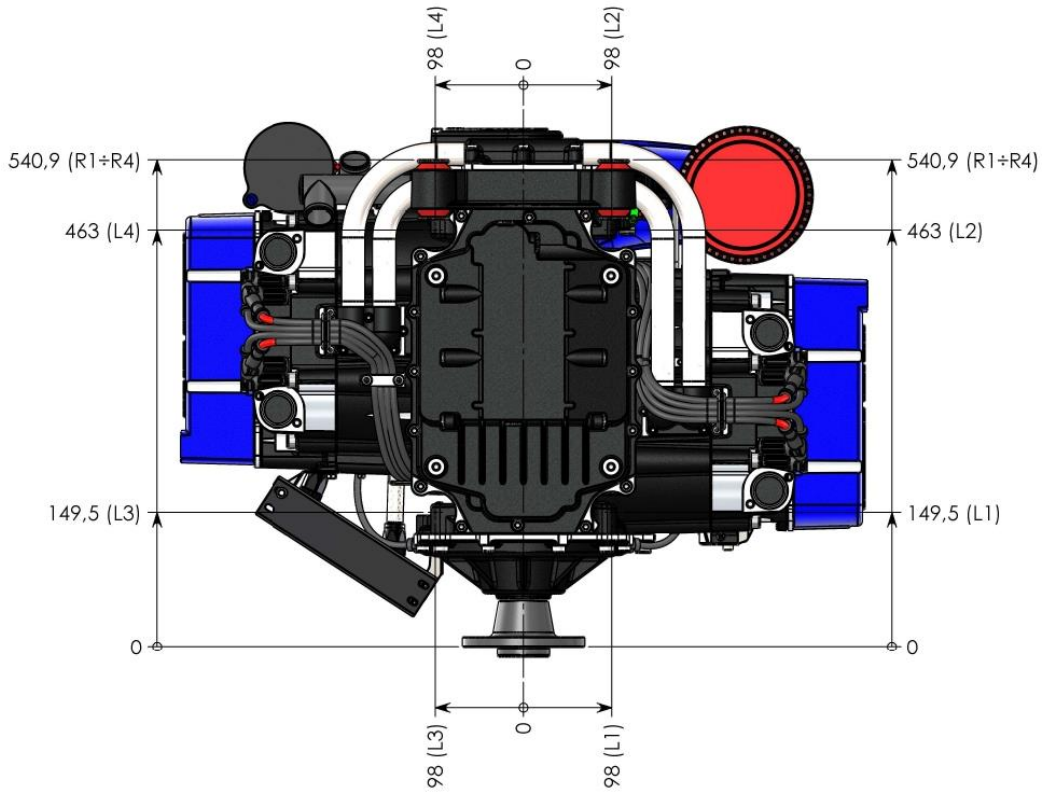



DATA SHEET SPIRIT 135Hp Direct Drive

Document
E-DTD.W017.001

Edition A	Revision 1
---------------------	----------------------

